

With just a motor and some pipe, you can build this efficient and inexpensive wind generator—and enjoy free electricity!

This project, originally written by Abe and Josie Connally in *Make: Magazine* Volume 5, can produce a sweet 20 volts in a steady 15 mph wind. While not enough to power your suburban split-level home, it's sufficient to make a small contribution towards a greener planet. More importantly, the project will give you a low-cost introduction to generators and wind power.



Tools

Drill and drill bits
Jig saw
Thread-tapping set
Pipe wrench
Crescent wrench
Screwdrivers
Vise and/or clamp
Volt/Ammeter

Wire strippers
Metal punch or awl
Tape measure
Marker, masking tape
Compass
Protractor

FOR MORE PROJECTS, VISIT: makezine.tv

PRODUCED BY:



IN ASSOCIATION WITH
MAKE MAGAZINE:



MAJOR FUNDING PROVIDED BY:



DISTRIBUTED BY:



Materials

MOTOR:

The motor used for this project is a 260 volt DC, 5 amp treadmill motor with a 6" threaded flywheel. However, you can use any other simple, permanent-magnet DC motor that returns at least 1 volt for every 25 rpm and can handle upwards of 10 amps. If you use a motor without a flywheel, you will have to find a hub for it. (A circular saw blade with a 3" shaft adaptor will work.)

Bridge rectifier (30-50A) with center hole mount, available at surpluscenter.com, item #22-1180

Mounting screw

Copper wire #8 (or larger), stranded. Buy enough wire to run from the top of the tower where you plan to mount your generator, to the batteries.

Spade connectors

Batteries (deep-cycle lead-acid storage batteries are recommended. We used two 6-volt batteries connected in series.)

BLADES:

2' length of 8" Schedule 80 PVC pipe.

¼" #20 bolts, ¾" long (6)

#20 washers (9)

Lock washers (6)

Hose clamp

Angle iron, 2" x 30"

TAIL:

12" x 18" (approx.) of medium gauge sheet metal

¼" sheet metal screws (3)

¼" bolts, nuts, and lock washers (3)

MOUNT FOR GENERATOR:

36" length of 1" U-shaped metal channel

1 ½" diameter flange

1 ½" diameter pipe, length determined by the height at which you'll mount your wind generator (ours was 4'), threaded at both ends

1 ½" diameter pipe, 6" long, threaded at both ends

½" diameter pipe union

Mounting screws

#72 hose clamps (2)

Estimated cost: \$200 - although this may vary depending on the availability of recycled parts.

FOR MORE PROJECTS, VISIT: makezine.tv

PRODUCED BY:



IN ASSOCIATION WITH
MAKE MAGAZINE:



MAJOR FUNDING PROVIDED BY:



DISTRIBUTED BY:



Before you begin:

You may find it necessary to modify these instructions, depending on what materials and tools you have at hand, and any improvements you might want to make in the design. Go ahead and customize the project and make it your own!

NOTE: Details regarding the design and construction of a suitable tower for holding and supporting the generator are not included here. You should consult with an expert about the best way to erect a permanent tower, and to connect the unit(s) to a wind storage and voltage regulation system.

Step 1. Cut the PVC for the turbine blades

Because the blades will be subject to significant stress, it is important to use Schedule 80 PVC. A plastics supplier may be able to provide you with a short section at reasonable cost. Do not use standard PVC sewer pipe.

First, clamp the 24" length of PVC pipe to a work surface to prevent it from rolling around. Next, place a length of angle iron against the PVC pipe. Holding the angle tight against the tubing, mark three lines 5 1/4" apart down the length of the pipe (see diagram on the next page).

Use a jigsaw with a medium fine blade to cut along the lines. While a single generator requires only three blades, the 8" diameter PVC provides enough raw materials for nine identically shaped trapezoidal blades, or enough blades for three generators.



FOR MORE PROJECTS, VISIT: makezine.tv

PRODUCED BY:



IN ASSOCIATION WITH
MAKE MAGAZINE:



MAJOR FUNDING PROVIDED BY:



DISTRIBUTED BY:



1. Lay out the cutting lines

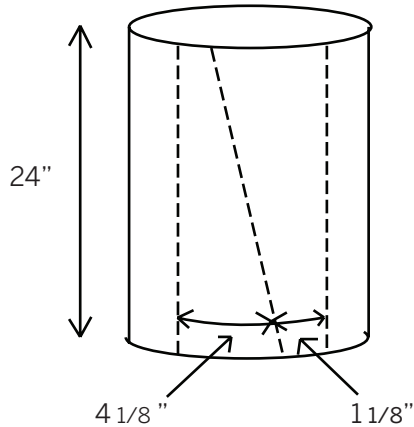

2. Cut 3 blades from tube

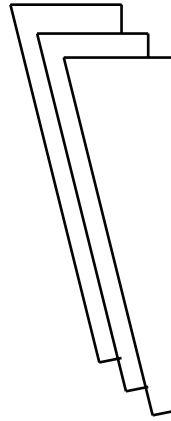

3. Trim a notch on each blade

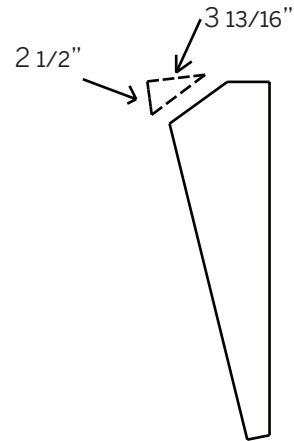

Step 2. Shape the blades

For best results, sand the blades into an airfoil shape as shown in the diagram below. This will significantly increase the efficiency of the blades.

The angled (leading) edge should be rounded, and the straight (trailing) edge should be pointed.

We tested a version of this project without sanding the blades and even in a steady wind, the generator produced only 10 volts. When we shaped the blades as indicated here, the voltage output more than doubled.



BLADE SHAPE

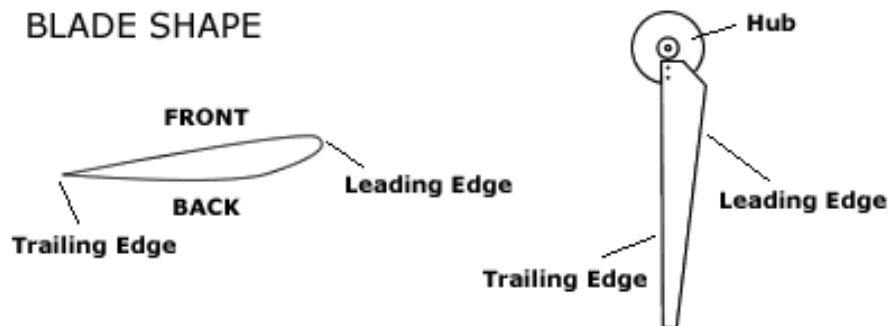

FOR MORE PROJECTS, VISIT: makezine.tv

PRODUCED BY:



IN ASSOCIATION WITH
MAKE MAGAZINE:



MAJOR FUNDING PROVIDED BY:



DISTRIBUTED BY:



Step 3. Drill and attach the blades to the flywheel

For each blade, mark two holes along the leading edge of the blade, opposite the notch. The holes are both $\frac{3}{8}$ " in from the edge; the first hole is $\frac{1}{2}$ " from the end, the second is $1\frac{1}{4}$ " from the end, as indicated in the photo.

Using the $\frac{1}{4}$ " drill bit, drill these holes in all three blades

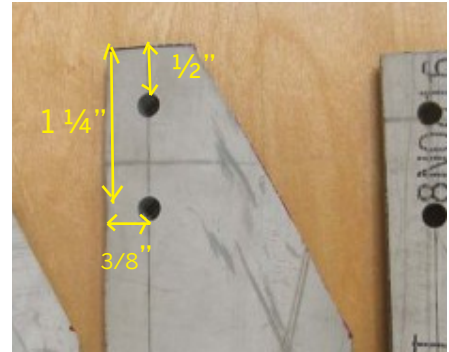

Detach the hub from the motor shaft. For our motor, we removed the hub by firmly holding the end of the shaft with pliers and turning the hub clockwise. (Our hub unscrews clockwise, counter to the usual direction.)

Using a compass and protractor, make a template of the hub on a piece of paper. Then mark three holes, each $2\frac{3}{8}$ " from the center of the hub, 120° apart. Place this template over the hub and use a metal punch or awl to punch a starter hole through the paper and onto the hub.

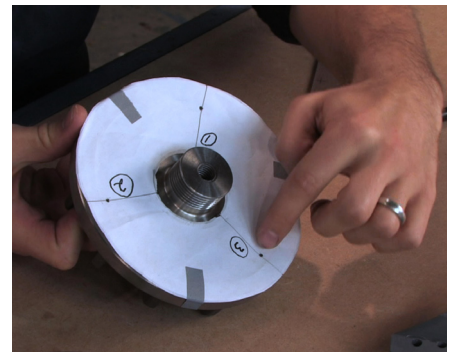

Drill the holes with the $\frac{7}{32}$ " drill bit, then tap them with a $\frac{1}{4}$ " tap. Drill only the first three holes at this point.

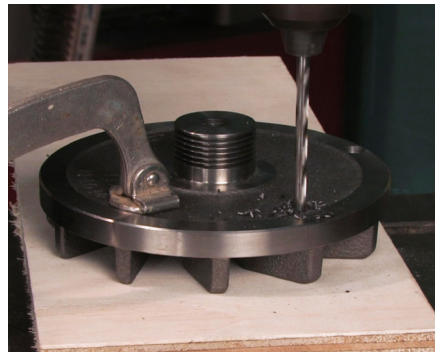

Attach the blades to the hub with a bolt through the second hole from the end of the blade.

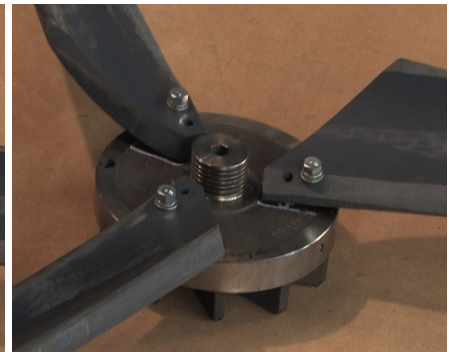

FOR MORE PROJECTS, VISIT: makezine.tv

PRODUCED BY:



IN ASSOCIATION WITH
MAKE MAGAZINE:



MAJOR FUNDING PROVIDED BY:



DISTRIBUTED BY:



Measure the distances between the tips of each blade, and adjust them so that they are equidistant. This is important for optimum efficiency. Mark and punch starter holes for the three inner holes on the hub through the empty holes in each blade.

Remove the blades, and drill and tap the three inner holes on the hub.



With all six holes now drilled and tapped, position each blade on the hub so that all the holes line up. Using the 1/4" bolts and washers, bolt the blades back onto the hub.

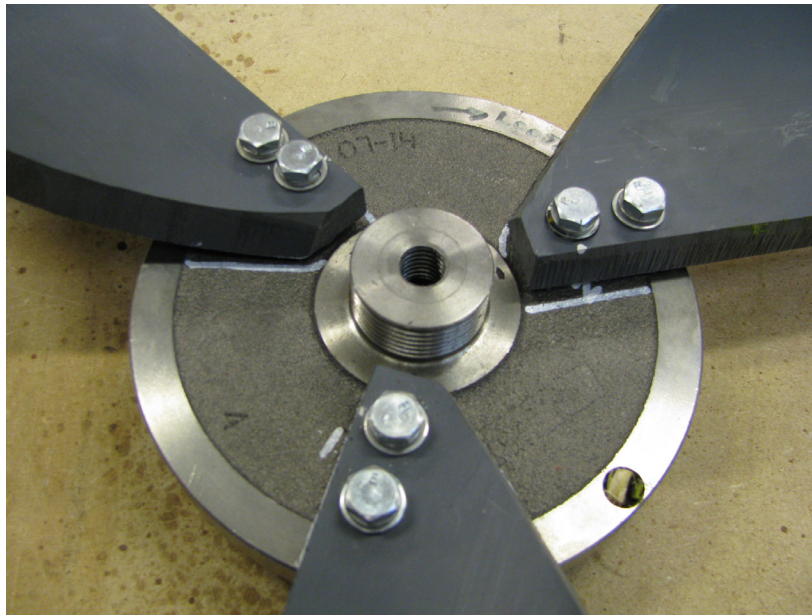

Step 4. Assemble the support frame

First, build the tail. Use tin snips to cut your tail pattern from a large piece of sheet metal. De-burr any sharp edges or corners with a file. (The dimensions are not critical.)

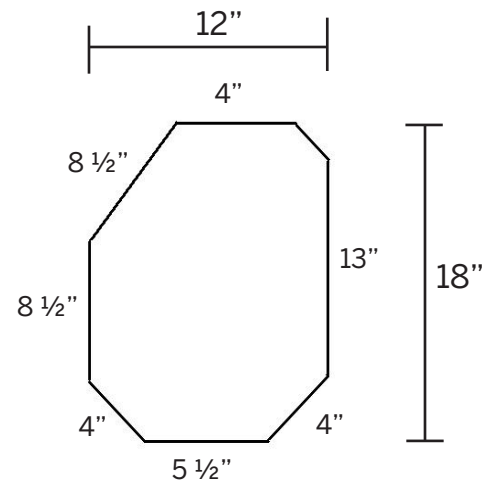

FOR MORE PROJECTS, VISIT: makezine.tv

PRODUCED BY:



IN ASSOCIATION WITH
MAKE MAGAZINE:



MAJOR FUNDING PROVIDED BY:



DISTRIBUTED BY:



Attach the tail to the metal channel using three $\frac{1}{4}$ " sheet metal screws. Attach the pipe flange to the metal channel using two sets of $\frac{1}{4}$ " bolts, nuts, and washers.



Next, assemble the stand for the wind generator. First, screw the $1\frac{1}{2}$ " pipe union to the pipe support. Then screw the 6" pipe into the other end of the union. Leave the union a little bit loose so the top pipe section can turn freely.



Finally, screw the frame and pipe flange assembly onto the 6" pipe. Tighten securely.

Step 5. Mount the generator

Using hose clamps, mount the motor on the end of the channel opposite the tail.

Drill a $\frac{9}{64}$ " pilot hole in the channel, near the end of the motor. Screw the rectifier to the channel using a sheet metal screw.

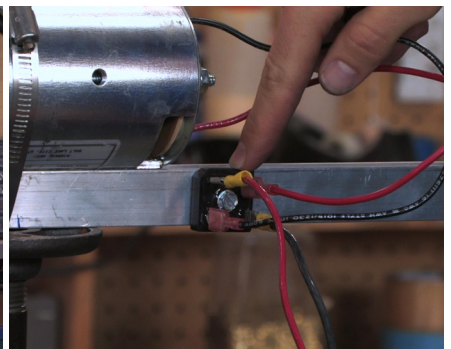

FOR MORE PROJECTS, VISIT: makezine.tv

PRODUCED BY:



IN ASSOCIATION WITH
MAKE MAGAZINE:



MAJOR FUNDING PROVIDED BY:



DISTRIBUTED BY:



Re-attach the blade assembly to the motor by spinning the assembly onto the threaded shaft. We recommend that you cut a groove into the shaft end so you can hold it with a screwdriver blade while you tighten the hub.

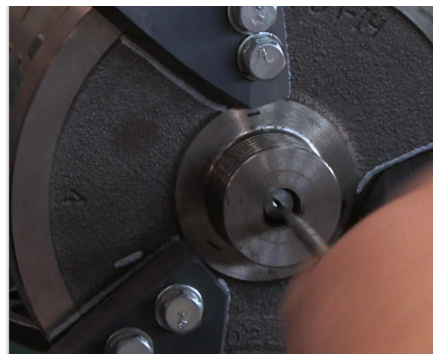

Step 6. Test the generator

We recommend performance testing your wind generator before permanently mounting it. Set it up in a location with a steady wind. Be sure the unit is well anchored before testing.

To test our wind generator, we mounted it in the bed of a pickup truck and drove it at a steady 15 mph down a deserted and straight stretch of road. Our voltmeter, connected to the bridge rectifier, registered 20-25 volts.



Step 7. The wind generator is complete. Now what?

Once you're satisfied with the performance of your generator, you may be wondering, "How many wind generators and batteries do I need to run my household?" The answer depends on more factors that we can easily cover here.

If you're serious about creating electricity from your wind generator, consult with an expert about the best way to erect a permanent tower and to connect the unit(s) to a wind storage and regulation system.

This website is an excellent resource:
<http://www.velacreations.com/offgridsystem.html>

FOR MORE PROJECTS, VISIT: makezine.tv

PRODUCED BY:



IN ASSOCIATION WITH
MAKE MAGAZINE:



MAJOR FUNDING PROVIDED BY:



DISTRIBUTED BY:



⚠ WARNING: This wind generator is presented as a simple introduction to wind power and is not intended for unsupervised operation during periods of high wind.

- Always ground and fuse your electrical system, as well as each component within it.
- Always stand upwind when near the wind generator to avoid flying debris in the event of failure.
- Unless your wind generator is unconnected and lying on the ground, it must be connected to a battery or other electrical load. Otherwise, the blades can spin freely and, in a high wind, attain dangerous speeds.
- In the event of very high winds, tie down the blades.

TELL US HOW YOUR WIND GENERATOR WORKS!

LEAVE A COMMENT UNDER THE VIDEO FOR THIS PROJECT AT <http://www.makezine.tv>

Resources:

Further information regarding one user's experience is available at <http://www.velacreations.com/maketower.html>

For more information on wind power, visit: http://www.otherpower.com/otherpower_wind.html

Use of the instructions here and on Make: television is at your own risk. Twin Cities Public Television, Inc., O'Reilly Media, Inc., the show's sponsors, producers, and distributors disclaim all responsibility for any damage, injury, and expense resulting from these projects.

Your safety is your own responsibility and that includes the proper use of equipment and safety gear and determination of whether you have the requisite skills to successfully and safely undertake the project. These projects are not intended for children.

It is mandatory that you understand that technology, laws, and limitations imposed by manufacturers and content owners are constantly changing. Thus, all Make: television projects may not work, may be inconsistent with current laws or user agreements, or may damage or adversely affect some equipment.

FOR MORE PROJECTS, VISIT: [makezine.tv](http://www.makezine.tv)

PRODUCED BY:



IN ASSOCIATION WITH
MAKE MAGAZINE:



MAJOR FUNDING PROVIDED BY:



DISTRIBUTED BY:

